

The "A"nnouncer



April, 2024

Newsletter of the Running
Board "A's"

www.RunningBoardAs.com

Volume 23

Number 4

The Running Board “A’s” Officers

President	Dave Allison 108 Ervin Rd. Pipersville PA 18947 (267)-733-3708
Vice President/Director	Chuck Savitske 3379 Reservoir Rd Hellertown, PA. (610)-573-4378
Secretary	Ken Nygard 426 Foulkeways Gwynedd, PA. 19436 (215)-283-7225
Treasurer	Cindy Chapman 5266 Valley Park Rd Doylestown, Pa 215-378-8753
Editor/Publisher	Dave Allison 108 Ervin Rd. Pipersville PA 18947 (267)-733-3708
Web Master	Dick Bettle 170 Crescent Road Florham Park, N.J. 07932 (973) 966-2947

The Running Board “A’s” club is a Model “A” Ford touring club. We are a region of the Model A Restorers Club (MARC). MARC recommends that all region members become members of MARC. See <http://model-a-ford.org/> for more information.

From the President

I would like to start off this month's column by thanking Doug Pyatt for his service to the club as Treasurer for the past year. Recently, Doug has become so busy with other activities that he felt that he could not give the Treasurer's job the time that he needed to do a good job. He officially resigned just before the planning meeting, but he plans to remain an active member of the club.

I am pleased to announce that Cindy Chapman volunteered to take on the job as club treasurer. She was approved for the position by the President, Vice President, and Secretary as well as unanimous approval by the club membership. Cindy has years of banking experience, so I'm sure she will do a good job. Thank You Cindy!

Historically, most of the club correspondence by mail concerns dues and other payments to the club. The club Treasurer has been responsible for this. Please note that going forward, all club correspondence should be sent to Cindy's address, found on the opposite page of this newsletter.

In the last month, we have had several successful events. We start out in April with a joint lunch with both the Active A's and the North Penn Model A Club. After that, there is the extremely popular Raise Your A Day, hosted by the Outwaters and then it's onto the Steve Ryan Mosel A Car Show in Trexlertown PA. More details about these events and more can be found in the Calendar of Events section of the newsletter.

Dave

\$

Treasurer's Report

Balance as of February 26,2024 \$2048.59

Income

Dues	\$15.00
Sale of Hat	\$10.00

Total Income \$25.00

Expenses

2023 Newsletter Printing And postage	\$160.00
---	----------

MARC region registration	\$10.00
--------------------------	---------

Total Expenses \$170.00

Balance as of February 26,2024 \$1903.59

Respectfully Submitted
Cindy Chapman
Treasurer

\$

On the cover: Model A's lined up during our March Planning Meeting.

Carburetor Pains

Over the last several months, I've heard complaints from some of our members about issues with their cars stalling at red lights and backfiring. There are several things that can cause this, but one of the most common problems can be a problem with the carburetor. This can be especially prevalent in "new to you" cars, where you don't really know the history of the car or it's components.

I know from experience that there is nothing more frustrating than stopping at a light and having your car stall on you. Then you have to hope it will start again!

It is equally frustrating to have your car backfiring as you go down a hill, up a hill, or when you shut it off.

I have had all of these problems and, although I may not be the best Model A mechanic around, I know what I did to fix the problem and it has stayed fixed for quite some time!

The carburetors that we are talking about here are Zenith carburetors. You may have a Tillotson carburetor, which was not original equipment on a Model A, but it still works fine if it is in good working order.

According to the *Model A Ford Mechanics Handbook, Volume 1* by Les Andrews, there were three different manufacturers of Zenith carburetors. Zenith 1, 2, and 3 were manufactured by Zenith, Holly and Ford respectively. They are all basically the same, with only minor changes. The drawing on the next page, taken

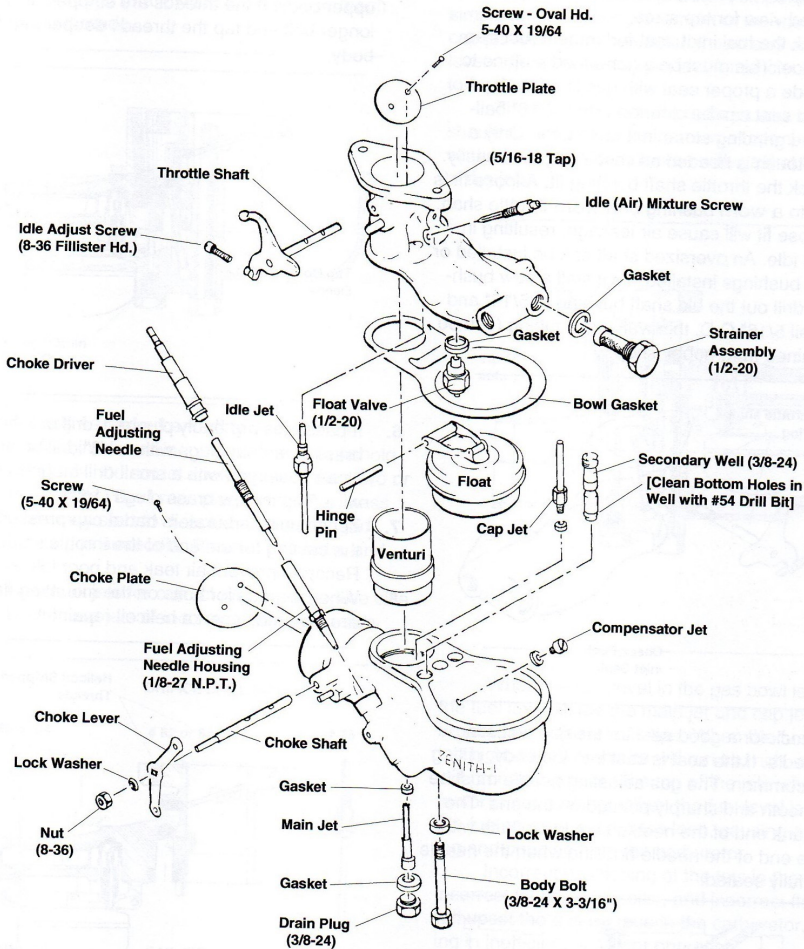

NOTE
 All jet threads and Idle Air Mixture threads are 5MM-75 pitch. Requires a special tap. A 10-34 tap can be substituted for 5MM -75 if necessary.

Zenith Carburetor Exploded View

from Les Andrews handbook shows a blowup of the carburetor.

Removal from the car and disassembly are pretty straightforward. Remove all the jets and clean out all the passages for the jets. If you use a wire or drill bits to do this, make sure that you are not enlarging any

of the openings. If you do, it will cause the engine to run poorly. A new gasket set from one of the Model A auto parts suppliers is usually a good investment. Many people recommend cleaning and reusing the original jets instead of replacing them with new ones. The new ones are not known for their quality and can cause more problems than they solve. Another good practice is to run the carb body and all of the parts through an ultrasonic cleaner. If you don't have one, I know of at least one member of the club that does have one and would probably be willing to let you use it for an hour.

Once you get everything cleaned up, it's time to put the carb back together. There are a number of things that you should look out for, but two of the main issues are the float level and the relation of the main

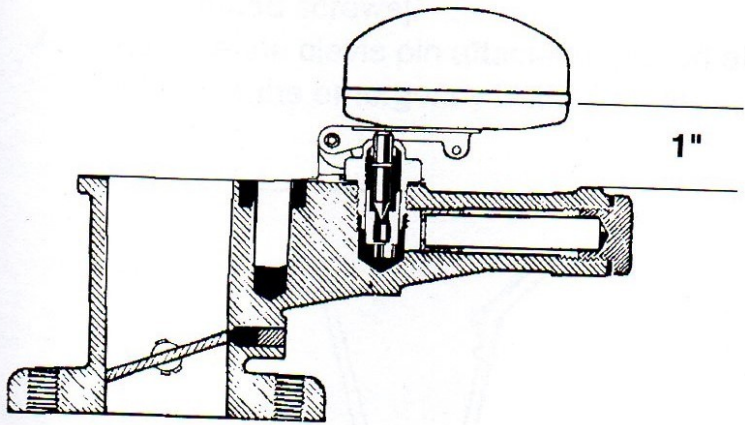

Float Level Adjustment

and cap jet to the carb. To get the float level adjusted properly look at the picture below. The handbook states that the seam of the float needs to be parallel to the body of the carb, so instead of bending the tab on the float to get the right height, just add gaskets between the float valve and the body to keep the float seam parallel and 1 inch from the carb body while turned upside down.

Once that's complete, the other thing you will want to do is to install the jets back into the carb. According to the diagram below, the cap and main jet have to be

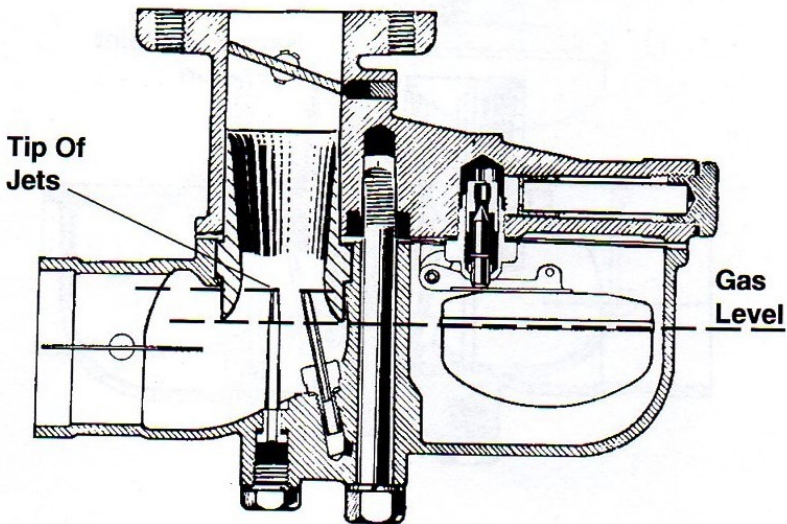

in the narrowest part of the venturi to work correctly.

If you don't do this, you can see in the drawing above that you can adjust the float level all day long, but if you don't have the two jets installed at the narrowest part of the venturi your float adjustment won't matter. These jets are also adjusted by adding or removing washers. DO NOT file or grind the tip of the jet. If you do, you will ruin the jet and make the car run even worse.

When putting the carb back together, make sure everything is clean and all the gaskets are installed properly, before you put the carb back on the car. This should definitely relieve the stalling at stop lights, and should help the backfiring situation.

If you are still having backfiring problems, it may be time to start looking at your ignition system, specifically the condenser. Not all condensers are made the same. Some are garbage right out of the box. If you have access to a known good working condenser, you may want to try it to see if it makes a difference. If it does, you solved your problem. If not, it's time to look at other aspects of the ignition system.

Either way, you are well on your way to making your car more enjoyable to drive.

Dave

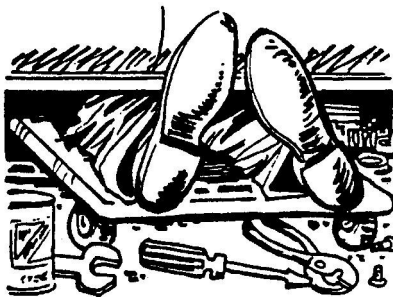

CALENDAR OF EVENTS

**Lunch at
Franconia Square
Café and Market,
513 Allentown Rd,
Souderton, PA 18964
Saturday April 13, 2024**

This is a joint event with the Active A's and the North Penn A's For those who want to travel together, we can meet at the Weis Supermarket parking lot at the intersection of Rt 113 and Rt 313 in Dublin at 11:15 AM. We plan to be at the restaurant by 12:00 noon. You can check out their menu [here](#). Please let Dave know if you plan to attend by April 6, 2024 so we can make reservations at the restaurant. Contact me at 267-733-3708 or at dalliso@mail.ptd.net.

Hope to see you there!

Dave



CALENDAR OF EVENTS

Model A Ford Safety Day. I'm sure we will have a great time!



Raise Your “A” Day

10 AM-Saturday, April 20, 2024

(or as some may prefer, “Up Your “A” Day”)

Bob & Bernadette are pleased to once again host “Raise Your A Day”. This is a fun day for you and your Model A to spend some quality time among friends looking for those annoying rattles, cracked frames, real or imagined suspension issues or maybe a quick lube and a top off of fluids. **Sorry, no oil changes** due to time constraints. As always, Bob’s lift will be available for you to check things out.

Please feel free to bring any small parts you may need for your “quick” repair. Donations of grease and transmission oil, etc., will be most welcome to help defray costs of this event.

Sandwiches will be provided by Bob and Bernadette. Please let us know what side salad, dessert, or soft drink you will bring to share.

Please let us know (973) 568-3525 or boutw@aol.com by **April 15** if you plan to attend so we can get a headcount for lunch.

Bob & Bernadette Outwater

32 Mason Farm Rd.,

Ringoes, NJ 08551; 973 568-3525; boutw@aol.com

CALENDAR OF EVENTS

April 28

2024

Sunday • 9 am to 3 pm

Trexlerstown, PA

Lehigh Valley Model "A" Club Presents

the **STEVE RYAN**
Model A/AA Show & Swap



Stock & Original Model A Ford & Era Equipment

Swap Meet • Concessions • Rain or Shine

Tech Session • Free Admission & Registration

Pin Stripping by Jim Brand • Paved Parking for Show Cars

Vintage Fords from 1903 - 1942 also welcomed.

Co-Host: LVMAC and the Goodwill Volunteer Fire Company

7723 Hamilton Blvd • Breinigsville, PA 18031 • Short Drive from Rt 78 and Rt 222

Swap meet spots are a S10 Donation • Model A / AA & early Ford parts only • NO household items • NO dolls/toys • NO modern tools

An associated car club is not required for show. Interest in Model 'A' Fords recommended.

RSVP your swap space or your club space for the day: 484.548.0632 or lvmodelclub@gmail.com

Lehigh Valley
Model 'A' Club



If anyone wants to travel together to the show, we can meet at 9:00 AM at the WAWA 1960 John Fries Highway (RT 663) Quakertown PA. Please contact me at 267-733-3708 or at dalliso@mail.ptd.net if you want to meet and travel together.

Dave

CALENDAR OF EVENTS

Overnight Trip to Rhinebeck Auto Show May 4th, and 5th 2024

We are meeting everyone at 9:30 Saturday morning in the BEER EXPRESS parking lot across from Perkins Pancake House Route 209 bypass in East Stroudsburg, PA. For those coming from this area, meet at Helms Garage, 408 West Hartford Street, Milford PA. We will then travel to the Milford Diner for lunch. Again we will be staying at Best Western in Kingston, New York. The number there to make reservations is (845)338-0400 . Any vehicle 1931 or older is free at the show. To register though go to: <http://www.rhinebeckcarshow.com> There are many vendors and a huge car corral of vehicles for sale as well. We usually leave sometime after 2:00pm to head home on Sunday. Remember we all go out to eat on Saturday night at The Hickory Grille. Steve Belton's cell is (908)334-8661, and my landline is (908)362-6344. Kathy's cell is: (908)655-8481.



CALENDAR OF EVENTS



9:00 AM to 3:00 PM

This is a great car show with lots of vendors and food for sale. Registration is \$8.00 if you are preregistered or \$10 the day of the show. Registration forms can be downloaded [here](#), or contact Chuck Savitske. If you plan to attend the show, contact Chuck at (610)-573-4378 so you can all get spaces close to each other.

From the Model A Ford Foundation Inc.

MAFFI Minute

Through the generosity of Donna Lewis, former MAFCA President and MAFFI Trustee, "Betsy", a 1930 Ford Model A has been donated to help raise funds for the expansion of the beloved Model A Ford Museum. The car remains in the same condition as restored by Red Grow in the 1950's. Enjoy driving "Betsy", your newest Model A, to your next cruise-in or car show. This is a truly historical vehicle, once owned by a MAFFI Hall of Fame inductee.

"Betsy", became famous as the best Model A in the world. The Ford Model A has gathered 32 top place trophies in the 34 shows which the car was entered. That includes two national shows in 1957 and 1962. Overall, the car won 39 trophies. It is said that Red Grow's car, "Betsy", was an inspiration at the time. It drove many people to do their best in restoring their own car. This urge to do the best restoration possible, developed the need for more information about how to do a better job. As a result, the Judging Standards evolved. We can thank Red Grow and the MAFCA founders for their vision.

In 1967, Red sold "Betsy" to a Ford car dealer named Dave Grubbs for \$5,000, an unheard-of price in those days. As a result, Dave Grubb placed the car in a glass cage centered in his dealer showroom. Now, you have a chance to own "Betsy" by entering a Sweepstakes through our website, <https://www.maffi.org/index.htm> , or scan the QR code and receive 20% more tickets for your Donation, available at checkout!"



Happy Motoring,
Cindy Ellenbecker, MAFFI Trustee-Secretary



March Events

We had three great events in March. The first was the firehouse breakfast at the Upper Black Fire House. There were only a few members that came to the event. More were planning to come but had to cancel due to illness. The breakfast and the company were still excellent.



Next was the How It's Made Tour where the group toured a local furniture maker in Blooming Glen., Roger Wright Furniture LTD. The turnout was wonderful with a dozen members present. I was not able to make it due to family obligations. Those that did attend, raved about the shop and showroom of the business. Thanks to Dennis Peters for setting this up.

Finally, there was the annual planning meeting on March 16th. As we like to say, "we meet to eat", but we also came up with some great events for the touring season. I sent out a list of events on a previous email, but if you didn't get it or deleted it, you can always go to our website,



www.runningboardas.com to see what coming up next. For those that receive a copy of the newsletter in the mail, a copy of the calendar has been included with the newsletter.



During the planning meeting, an interest was expressed to go back to a restaurant for our annual holiday. Doru and Bob Outwater volunteered (ok, were volunteered) to investigate restaurants and costs for the event. Their investigation led them to the [Harvest Moon Inn](#) in Ringoes N.J. The cost would be about \$47 per person including tax and gratuity. It is available on Saturday December 14 for the event. Please let me know ASAP if you have any feedback concerning the event,
Dave





**Membership Application
For the Running Board "A's"**

Name _____

Address _____

Telephone Number _____

Email address _____

Dues are \$15.00 annually. Please make checks payable to:

Running Board "A's"

Mail to:

Running Board "A's"

C/O Cindy Chapman

5266 Valley Park Rd.

Doylestown, PA. 18902

If renewing, please underline any information that has changed

Running Board "A's"

5266 Valley Park Rd

Doylestown, PA, 18902

First Class Mail